

ACHILLE

PULSANTE-PUSH-BUTTON

ITA

STRUTTURA: Pulsante in policarbonato con estetica in zama (cromo o oro), UNI EN 81-70(cifra in rilievo);

MONTAGGIO: il pulsante viene inserito frontalmente in uno scasso 32,2 e fissato tramite ghiera filettata;

SPESSORE PIASTRA: da 0,7 a 3 mm;

PARTE MOBILE: in policarbonato con superficie esterna in acciaio INOX AISI 304 con possibilità di finitura PVD oro;

LEGENDA: cifra in rilievo + braille (NON NECESSITA DI TARGHE AGGIUNTIVE PER IL BRAILLE)

CONTATTI: 1 o 2 microswitch.

TIPOLOGIE DI CABLAGGIO: morsetti e precablato.

ALIMENTAZIONE CORONA : (4 x LED) 12 o 24 VDC I=20mA.

CORSA PULSANTE: 1,2 mm.

VITA MEDIA:1.500.000 di attivazioni(24V,20mA)

GRADO DI PROTEZIONE: IP51. IP54 con molla siliconica e O-ring.



ENG

Body: polycarbonate push button with zamac fixture (gold or chrome finishing), tactile legend (EN 81-70 norm) and Braille;

Mounting: the push button is put into the cutout (32.2) from the front and fixed by threaded ring;

Faceplate thickness: 0.7mm to 3mm;

Pressel: polycarbonate with stainless steel AISI304 or gold PVD-coated finishes;

Legend: tactile legend and Braille included in the push button (without added plates for Braille);

Contacts: 1 or 2 microswitches;

Wiring: screws connectors or prewiring;

Halo Power: (4XLED) 12-24V DC

Stroke: 1,2 mm

Lifetime: 1.500.000 activations (24V, 20mA);

Degree of protection: IP51. IP54 with silicone spring and O-ring.

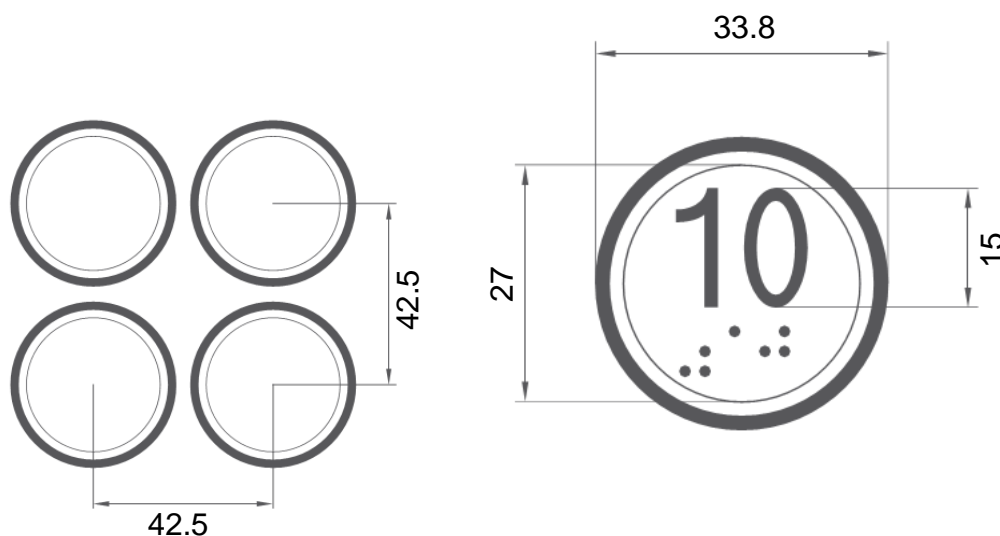

SCASSO/CUT OUT

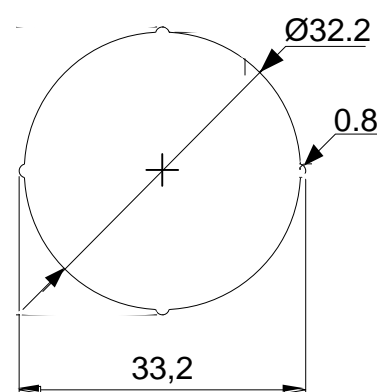

VEGA

ITALIAN STYLE FOR LIFTS

ACHILLE TH BLAMP

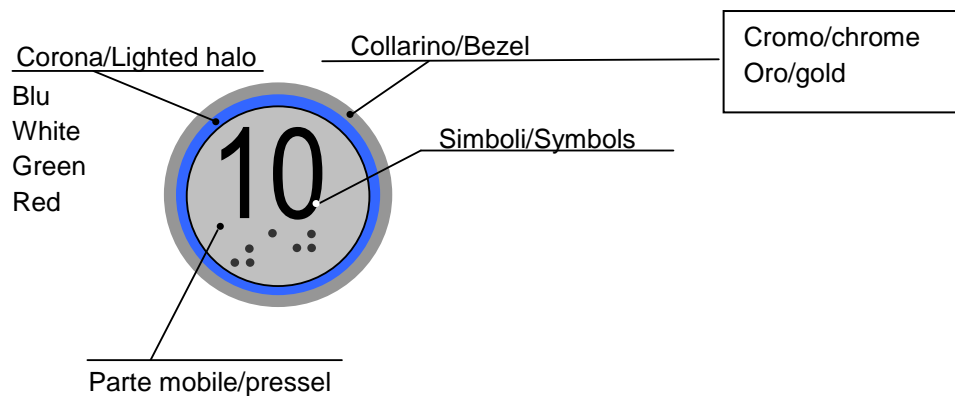

AMP connector/
Connettore AMP

Schema di collegamento/
wiring diagram

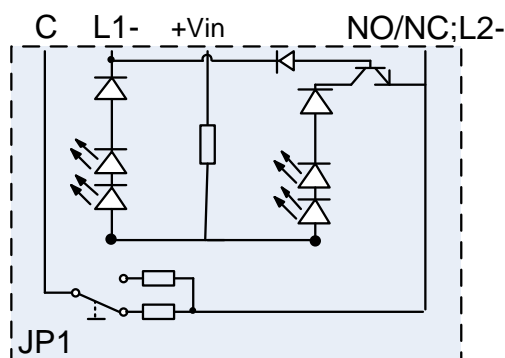
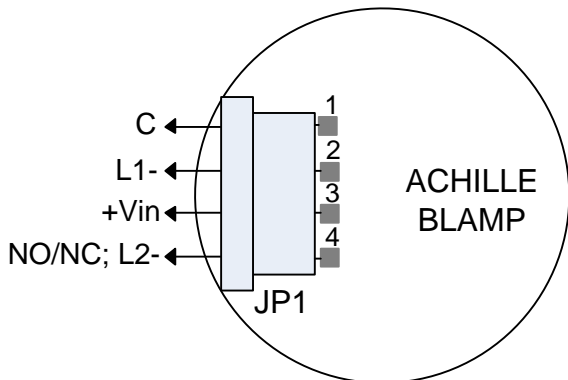

J1

C: comune contatto/ common contact;















L1-: corona 1 (-) / lighted halo 1 (-);

+Vin: Alimentazione +12V o +24V / Power supply +12V or +24V;

NO/NC; L2-: Contatto normalmente aperto o normalmente chiuso; corona 2 (-) / normally open or normally closed contact; lighted halo 2 (-)

SIMBOLI E LETTERING / SYMBOLS AND LETTERING

Simboli/Symbols

< >		Apriporta/open door
> <		Chiudiporta/close door
F		Freccia/Arrow
TEL		Cornetta telefono /telephone handset
-7...36		Numeri/numbers [-7,-1,0...36]
1/2...5/6		Mezzi piani/Half floor [1/2...5/6]
S		STOP
N		Neutro/Neutral
2F		Doppia freccia/ Double arrow
V		Ventilatore/Ventilator
O		OTM
TLB		Cornetta telefono+Braille/ Telephon handset+Braille
INT		Interfono
A		Allarme/Alarm
AY		Allarme/Alarm

Lettering

A	B
C	CH
CP	DR
E	ES
G	G1
G2	K
KG	LB
LG	M
MZ	P
R	RB
RC	RH
RJ	S
SB	SS
T	U
UG	OH
1H	

LEGGERE ATTENTAMENTE LE AVVERTENZE SULLA PULIZIA !!!

I nostri pulsanti devono essere puliti solo ed esclusivamente con un
PANNO IN COTONE E ACQUA CALDA !!!



Evitare qualsiasi utilizzo di sostanze chimiche, soprattutto per le
superfici in plastica.

Molti prodotti Vega sono realizzati in policarbonato, ABS, metacrilato o nylon 66.
L'utilizzo di prodotti di pulizia contenenti anche in minima parte ammoniaca,
idrocarburi, soda caustica, acido cloridrico, acido nitrico, acido acetico, alcol etilico,
alcol metilico sono assolutamente vietati.

CAREFULLY READ THE WARNINGS FOR CLEANING !!!

Our push buttons must be cleaned only and exclusively with a
COTTON RUG and WARM WATER



Avoid every use of chemical substances, above all for plastic
surfaces

Most of Vega products are made in polycarbonate, ABS, methacrylate or Nylon 66. The
use of many cleaning products with caustic soda, hydrocarbons, hydrochloric acid, nitric
acid, acetic acid, ethyl alcohol and methyl alcohol are strictly prohibited

VEGA

ITALIAN STYLE FOR LIFTS

VEGA STYLE LIFT s.r.l., Via Monte Vettore, 12 –

63845 Ponzano di Fermo (FM) Italy – P. Iva 02018560447

Tel. +39.0734.631941 – Fax: +39.0734.636098